



SPHEROS

Products from the bus specialist

Best Bus Climate

This is our domain:

Heating – **V**entilating – **A**ir **C**onditioning





When the brain starts breathing, ideas will flow...

Best Bus Climate 3

Air conditioning 4

Heating systems 6

Hatches / Fans 8

Control units 10

Bus climate worldwide 12

Environment and the future 14



Heating – Ventilating – Air Conditioning, we manage it all!

Buses are conquering the world. They cross deserts, battle the adverse conditions in arctic regions and toil on scheduled routes through megacities on all continents. Nowhere are the demands on ventilation and air conditioning more exacting than in the bus. This is where the technical and market knowledge that flows into all our products from controls to the roof hatch comes into play. And the Spheros Group reliably offers this at all its locations, all over the world. For many years we at Spheros have been focusing our commitment in the field of air conditioning and ventilation systems exclusively on the bus business.

Rather than limiting ourselves to the development of individual components, we place emphasis on the integration and linkage of sophisticated air conditioning systems, including intelligent controls. Cooling, heating and ventilation: we manage it all.

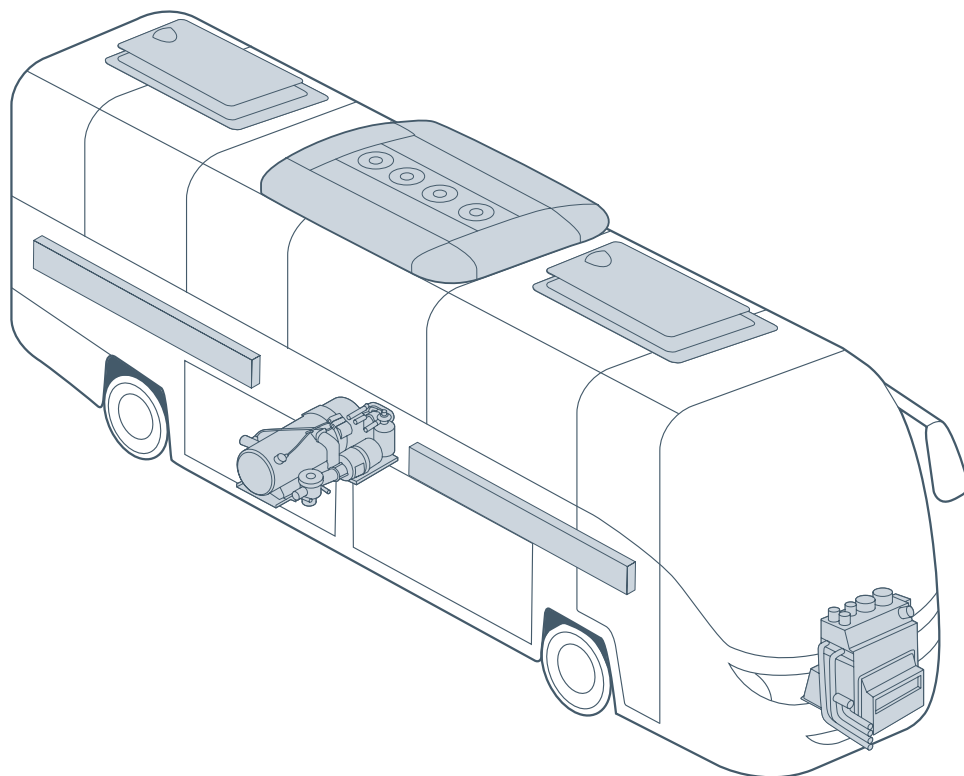



Aerosphere Alu: aluminium comprises 98% of metals used in the cooling circuit.

The high-tech crown: top efficiency in every sector

To anyone who knows anything about cooling, it's not just a matter of generating cold, but creating a feeling of well-being and safety as well. In an enclosed mobile space as large as a bus, an extremely wide range of temperature conditions can be felt at different seats. Even more diverse are the exterior contours of a bus.

That's why we develop almost individually tailored cooling concepts. Whether powerful and robust large aggregates for extreme conditions, stringent technical requirements or functionally-oriented units for growing markets outside Europe, we have the right solution. To us, cooling means not only generating cold. A correctly temperature-controlled bus is, after all, the crowning finish for driver and passengers.



Citysphere: compact performance with intelligent air distribution.



CC 355 shows what it can: powerful cooling on narrow roofs.

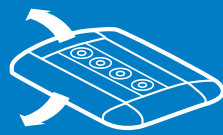

The big ones

They deliver strong performance as the weight decreases: the new product we are referring to is REVO. Radically reduced and intelligently composed components achieve hitherto unrivalled LCC. Rigid plastic is precisely crafted in this consistent lightweight design concept and about 98% of components containing refrigerant are nowadays made of the extremely lightweight material aluminium. Speed-controlled brushless EC fans, optimised heat exchangers and sophisticated refrigerant feeds guarantee improved performance.

The compact ones

Other requirements apply to comfort in the city, mini or midi bus. For example, the compact Citysphere air conditioner with the wind chill effect developed by us always creates pleasant temperatures, quite simply due to increased air movement. No maintenance costs and extremely low service expenses. The city bus unit thus achieves unparalleled LCC. Alternatively our CC series: conceived for mini and midi buses, it is easy to install and even fits on narrow roofs.



Production and development in Neubrandenburg.

The special ones

We also provide special air conditioning concepts for special requirements. With our water circuit heated and cooled Aquasphere, for example, we can create a cosy atmosphere for ultimate relaxation. Its design harmonises with the bus contours, its weight can

be individually distributed and it can be operated with fresh, mixed and re-circulated air. Designed as a split-type unit, it is already filled with refrigerant and achieves cooling capacities from 17 to 54 kW. These split units are always customised solutions which can only be realised in close cooperation with the manufacturers.



Thermo S: Innovative heating technology, because the future should be clean.

The Thermo series – best performance in every class

Our roots lie in the manufacture of bus heating systems – that is quite evident. The Thermo series of heaters has been developed, tested and produced at Gilching and Neubrandenburg for the past 50 years. Hard to believe that there's still something new to discover! But the standards of well-being and environmental compatibility are constantly increasing, and thus the quality of our heaters.

We are proud to present the new generations of powerful and eco-friendly Thermo series which caters for the needs of a wide variety of markets and customers. Or the GBW heater, specially developed for gas-powered buses, which makes us the only manufacturer worldwide so far to satisfy this requirement profile.



Aquavent 6000 SC: Brushless EC pump with magnetic coupling.



Only available from us: GBW gas heater.

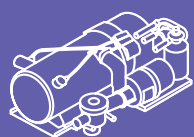

The modern ones

The innovative heating technology in the Thermo S is the logical response to future requirements in the bus. Environmental compatibility, low LC costs and increased efficiency were the focus of development, together with ease of service and maintenance due. The Thermo S enables fast data retrieval by thermo test diagnosis and is also compatible with OE diagnosis tools. With five power levels from 16 to 40 kW and extended service life, the Thermo S is deservedly our top model. It already stays well within the future emission limits, is noise-optimised and suitable for operation with alternative fuels. That smells like a great future!

The robust ones

The Thermo E was developed primarily for markets in which the performance, robustness and cost-effectiveness of heaters is of major importance. The result is a series of products which draws on the many years of experience with successful predecessor models. The 20 and 32 kW versions cater for the requirements of all applications and great trust is placed in them due to their high degree of reliability. Service and maintenance expendi-

ture, like operating costs, are kept to a minimum. Optimised heat transfer ensures improved efficiency with low fuel consumption and exhaust emission values substantially lower than required by law. The simplest maintenance through diagnosis by blink code makes Thermo E a trusted friend.

The special ones

With a view to the increasing requirements for protection of the environment, there is a strong trend

to gas-powered buses. In support of this trend, as the world's only manufacturer of gas heaters for buses we have pointed the way and convinced customers with the development of our GBW 300. The GBW not only stands for tailor-made, cosy warmth and low-noise operation. In natural or liquid gas operation it also satisfies current ecological criteria. Compatible with all existing mechanical system connections, due to its small size the GBW 300 is ideal for installation in gas-powered buses.



Cutting edge heating technology: decades of experience at the Neubrandenburg plant.



Vision glass roof hatch: imparts a feeling of well-being and an intense travel experience.

Fresh air for a good climate

As emergency exits, roof hatches contribute to safety in the bus. That is no secret. We as market leader for roof hatches are well aware how important hatches are with their supporting function in the bus air conditioning system and which role they play for the well-being of the passengers and driver. Hatches quickly and effectively provide fresh air, far away from the dust of the road, through optimum airflow and variable positions while stationary or in motion. With our intelligent control in the interplay with air conditioning systems they create real synergies.

Roof hatches are simple, durable and almost maintenance-free bus climate elements which simply discharge the stale air by means of integral fans when the bus is parked. They effectively provide for the well-being of passengers and a fatigue-free driver, making a major contribution to safety on a bus journey.



Premium roof hatch: up to four roof hatches can be electrically controlled by digital hatch control.



Modus roof hatch: works reliably and supports the cooling action with an integral fan.

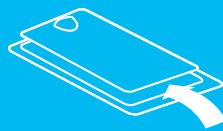

Premium roof hatch

The Bus Top Premium was developed mainly for the Central European market with its high quality and durability standards. It is exclusively electrically operated by integral electronics, has a particularly wide opening and is almost maintenance-free. Rain and theft sensors are available as an option.

Vision roof hatch

Besides fresh air, our transparent Vision roof hatch admits light into the interior of a bus and additionally contributes to the well-being and reduced fatigue of passengers and driver. Manually or electronically (Vision Flex) operated, with its aluminium frame it is simple to retrofit and likewise almost maintenance-free.

Modus roof hatch

The search for reliable and economical solutions for roof hatches ends here: our Modus series with plastic frame and cover. Whether City, Coach or Comfort, or the new and easy-to-install Cool with its integral fan (200 m³/h): the Modus series quickly ensures a plentiful supply of fresh air.

Elexx roof hatch

Primarily designed for the requirements of the North American market, with its special hinged opening the Elexx is an optimum multi-purpose solution. The almost 70 mm wide ventilation slit ensures an immediately perceptible “super ventilation”. Its low weight and simple glue installation has helped the Elexx become a best-seller not only in the USA.

Mushroom vent and integrated fan

Often the simplest solution is so obvious. Whether with built-in mushroom vents or fans integrated into roof hatches: through simple ventilation via the roof a perceptible temperature reduction can be achieved before starting off, supporting the effect of the air conditioning and going easy



Mushroom vent: discreet but effective.



Spheros quality from Finland: roof hatch production for safety and reliability.

on the motor and environment by shortened switching times and unnecessary idling. Many customers refer to these solutions as “simple air conditioners”, which is not quite accurate, but appropriate nevertheless.

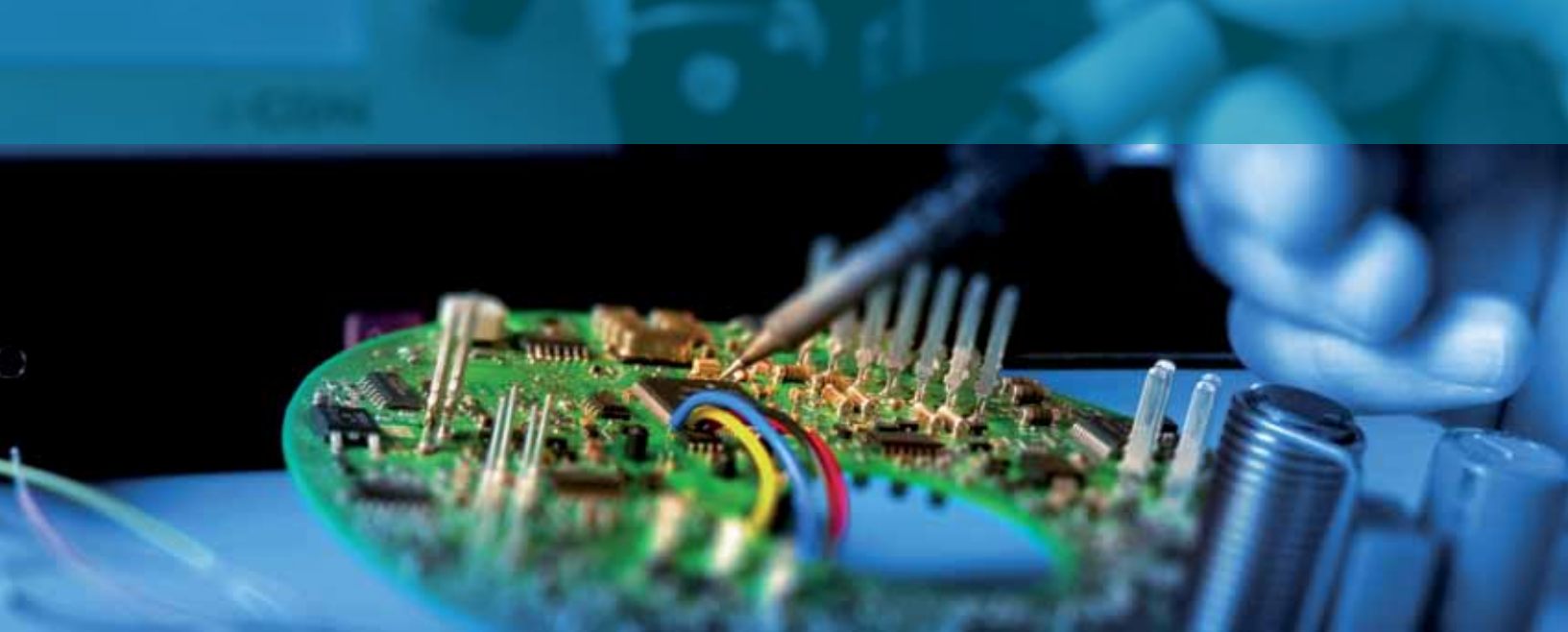

Sophisticated thermo management for modern bus air conditioning.

Intelligence for the bus climate

Intelligence and management are of vital importance in the control of all components for optimum bus climate. Behind the efficient and error-free control of the heater, air conditioning unit and ventilation is the intelligence of the software. More and more components will be integrated into climate control of the future, and the operating states of the vehicle will be read out and applied. This sophisticated method of thermo management is for our customers and us the most important task of modern bus air conditioning today and in the future.



Individual climate control: an indulgence for the passenger.



SDC coach: integrated controls in the driver's section.

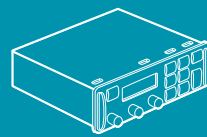

SDC competence: Spheros digital control

The requirements of tomorrow lie in the intelligent interconnection of HVAC components in the bus – as we recognised at an early stage and consciously invested in the development of the electronics. In the past few years innovative products have been derived from this principle. Our latest climate controls can already be employed cost-efficiently. Examples are the LIN-bus based hatch control, likewise the CAN-based diagnosis for the Thermo S. The air conditioners are equipped with sensors and speed-controlled fans which are developed to our specifications. With SDC we are investing further in these central controls, because they are the future of bus air conditioning.



Our processes and development flows are orientated to the recognised spice model.

Concept of synchronous load thermo-management

Increasing complexity in the control of optimum interior climate in modern buses calls for continuous synchronised and trouble-free linkage of all components involved. In future, air conditioners, heaters and roof hatches will be informed about the operating status of the moving (or stationary) bus and balanced accordingly, a feature

that is likely to become important in view of the increasing electrification of buses. We call this demand-oriented control “synchronous load thermal management”. Spheros has been steadily increasing its commitment in the past few years and positioned itself as a development and system partner for vehicle electronics and complete control in buses worldwide.



SDC City (top); SDC Coach (bottom)



Buses: This is our domain

For over half a century Spheros products have set the standards for heating and air conditioning of modern buses. Our development and quality processes, the training of our employees, the layout of production and the goals of Spheros are focused on effective heating, air conditioning and control systems in the bus. In ever shorter times we are developing ever better solutions for ever better conditions.

Our motto is “100 per cent bus”. For this we research and work more than others on future-oriented concepts, for example:

- Resource-saving air conditioning systems
- Alternative refrigerants
- Individual air conditioning and heating
- Improved efficiency
- Weight reduction
- Low LCC
- Air conditioning for alternative drive systems



Bus climate worldwide



World Time Map

Europe

Gilching
 Neubrandenburg
 Barcelona
 Istanbul
 Turku
 Lviv
 Moscow

Middle East

Dubai
 Jeddah

South Africa

Cape Town
 Durban
 Johannesburg

Asia

New Delhi/Noida
 Dharwad
 Yangzhou
 Hongkong
 Kuala Lumpur
 Busan
 Wuxi

North America

Canton/Michigan

South America

Toluca
 Bogotá
 São Paulo
 Caixas do Sul

We're everywhere our customers need us

The company's main office at Gilching sees itself as a mediator which coordinates worldwide streams of competence, with the aim of realising the best on-the-spot technical solutions. With this ideal blend of global and local we can always guarantee customer proximity and outstanding service.

We can develop and produce every single product at the ideal location. Spheros customers thus receive individually tailored, reliable yet cost-effective solutions – European technology at local prices – always incorporating the customary high Spheros standards of quality and reliability. To meet these demands we are always in action somewhere in the world.



Concept for a sustainable future

The results of our many years of research and development deliver important stimuli in the responsible management of existing resources. The following are some of our achievements in terms of new system and product concepts:

- Reduction of unit weight, e.g. by the use of aluminium components
- Use of recyclable materials
- Reduced fuel consumption
- Operation with alternative fuels or drive concepts
- Lower emissions (noise, exhaust)
- Alternative energy generation, e.g. solar electricity for the fan
- Efficient management of vehicle energy

We will continue to be committed to the distinction “Blue Bus Climate” in future.



Precision climate design
in a pro-active way.

